



eljen Geotextile Sand Filter

Septic System Owner's Manual

*How your septic system works
and how to keep it working
for you and the environment*



eljen
CORPORATION

Innovative Environmental Products and Solutions Since 1970



ejjen Geotextile Sand Filter

Table of Contents

Introduction3

GSF Performance and GSF System Description4

GSF System Operation5

Nature of Household Sewage6

The Septic System6

The Septic Tank.....7

The GSF System8

Septic Tank Effluent Filters.....9

Pumped Systems9

System Care and Maintenance10

Septic Tank Pumping.....10

Potential System Problems.....11

Preventing System Problems12

Service and Maintenance Record14

Map of Your Septic System14

System Details.....15

Introduction

A new residential septic system can cost anywhere from \$4,000 to more than \$20,000 to install. If it is not maintained, it will become clogged and overflow on the ground or cause wastewater to backup into the house. Rebuilding a failed system may cost several thousand dollars and create a tremendous nuisance.

System failure is easier and more affordable to prevent than it is to correct. By keeping harmful materials out of the system and by pumping out the septic tank at least every 3 years, the homeowner can protect his or her system against premature failure. The approximate \$300 cost of having the tank pumped is wise insurance to protect a substantial investment.

This manual outlines the principles of septic system operations and explains the basic maintenance procedures that will lengthen the life of your system. If properly operated and maintained, your Eljen GSF system can provide many years of trouble-free service.

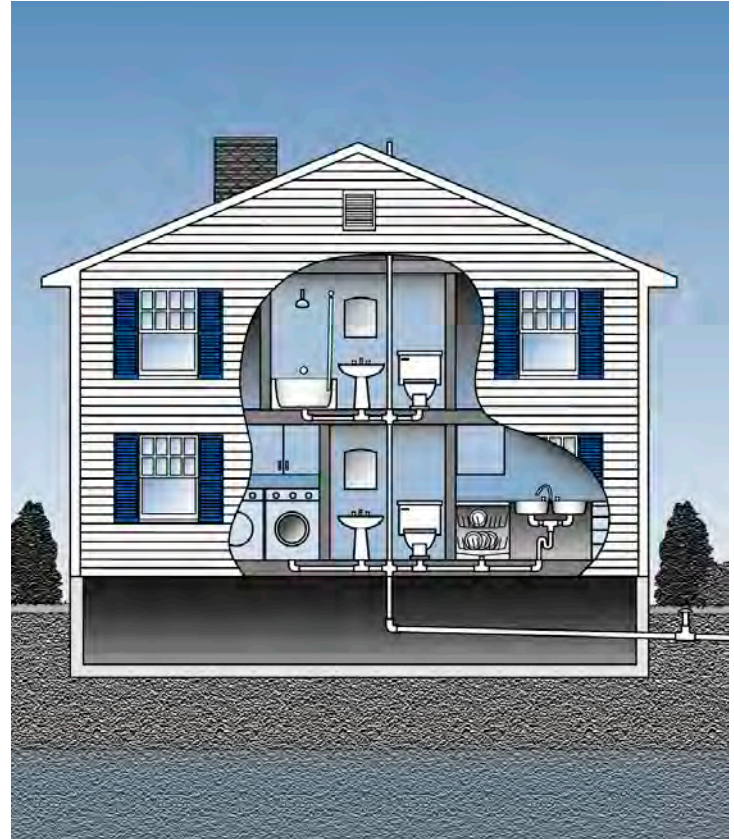

Tested for Proven Performance

The Eljen GSF system technology is based on research conducted by nationally-recognized engineering scientists from the University of Connecticut. Eljen has over 30 years of success in the onsite wastewater industry, with tens of thousands of systems currently in use. The GSF is recognized by regulatory officials and experts in the industry as the most reliable pretreatment technology in the marketplace today.

The GSF technology is based on scientific principles which validate that improved effluent quality provides increased soil absorption rates. Third-party analysis has confirmed that the GSF's proprietary two-stage Bio-Matt™ pre-filtration process improves effluent quality, resulting in greater reliability and ease of operation compared to other treatment products available today.



eljen Geotextile Sand Filter

GSF System Description

The Eljen GSF Geotextile Sand Filter system is a cost-effective upgrade from other septic technologies. Unlike other systems that treat effluent only once, the GSF's patented Bio-Matt™ pre-treatment process treats septic effluent twice. That means that the soil can absorb the effluent more easily, resulting in a better-performing system in a smaller area than other systems.

HOW THE GSF SYSTEM WORKS

- Incoming effluent and bacteria flow through the perforated pipes which distribute the effluent over the modules.
- Open air channels in the modules allow beneficial bacteria to grow on the Bio-Matt fabric and treat effluent.
- A geotextile fabric covers the top and sides of the GSF modules, protecting the system's sand and soil from fine particles that can clog the system. It also helps maintain effluent storage inside the modules.
- After effluent passes through the GSF modules, a lighter, secondary biomat forms on the layer of sand below the system, where the treatment process is continued.
- Treated effluent is then absorbed by the native soil where final filtration takes place.

GSF System Operation

This schematic shows the inner workings of the GSF module and the overall operation of a GSF system.

- **Porous Top of the GSF System**

allows evapotranspiration and oxygen exchange for better effluent treatment.

- **Anti-Siltation Fabric**

keeps fines out of the GSF system

- **Untreated Effluent**

- **Bio-Matt™ Fabric**

- **Cusped Plastic Core**

provides separation between layers of Bio-Matt™ fabric. Maintains structural integrity of modules & aids oxygen transfer. Increases treatment surface area and effluent storage capacity.

- **Filtered Effluent**

- **Treated Effluent**

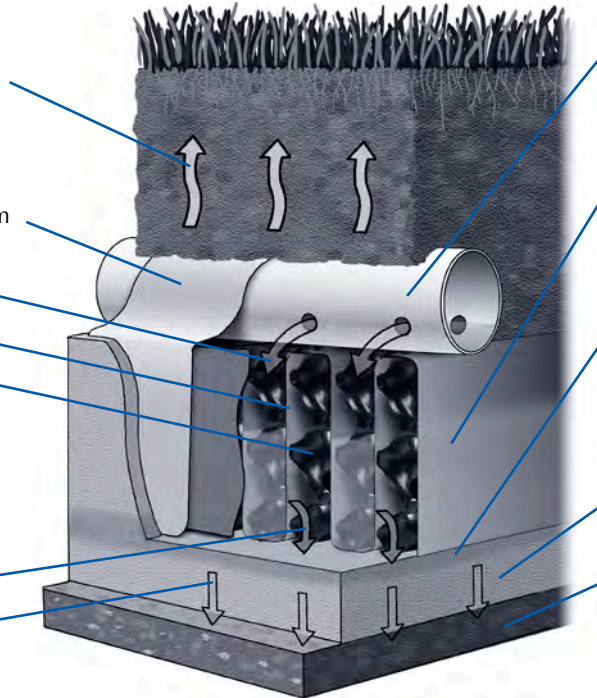

- **Perforated Pipes**

distribute effluent to the GSF system. Pipes are secured to the GSF modules with preformed metal clamps.

- **Primary Treatment Zone**

forms on Bio-Matt™ fabric. Significant fabric is provided for every ft² of soil interface.

- **Secondary Treatment Zone**

forms at sand layer. Long term acceptance rate of this biomat layer is significantly increased as compared to conventional systems.

- **Specified Sand Layer**

provides additional filtration

- **Native Soil or Fill**

provides final filtration

The Nature of Household Sewage

Household sewage is a combination of wastewater from several sources including sinks, toilets, showers, washing machines, dishwashers, and garbage disposals. The largest source of household sewage may vary depending upon the number of residents and water-using appliances within the home. Organic matter comes mostly from toilets and garbage disposals, while sinks, showers, and washing machines contribute large amounts of wastewater containing only small amounts of soap and dirt (including grease, detergents, lint, and vegetable matter).

NOTE: Most states require much larger septic tanks and even larger system sizes if garbage disposals are used.



The Septic System

Your septic system is a two-part sewage treatment and disposal system buried in the ground. It is composed of a septic tank and a treatment system, and may have filters, pumps, and other components depending on your location and system demands. The sewage generally flows by gravity: first, into the septic tank where larger particles settle out and some primary decomposition takes place, and then into the GSF system where it is further decomposed before slowly soaking into the soil.

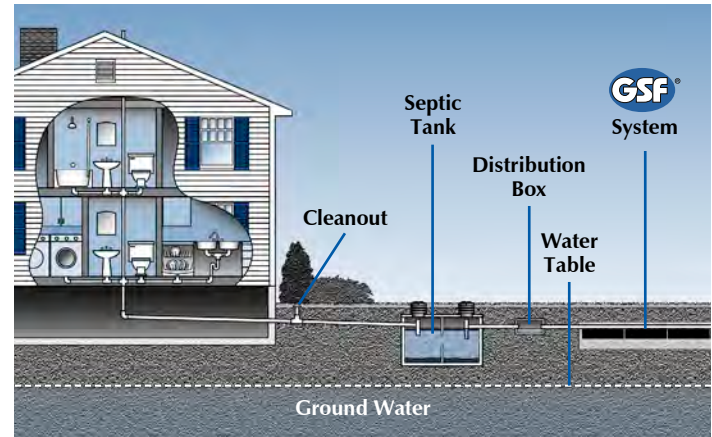

The Septic Tank

Untreated household sewage would quickly clog any system if applied directly to the soil. The function of the septic tank is primarily a settling tank allowing solids to settle to the bottom of the tank while a somewhat cleaner liquid is discharged to the GSF system for additional treatment. Septic tanks may contain one or more compartments, or the designer may have specified two or more tanks for your system.

Regardless of the number of compartments or tanks in your system, the basic principle is the same. Within the tank, as shown below, four important processes take place.

- The heavier, solid particles in the sewage settle to the bottom of the tank forming a layer of sludge. Lighter materials, including fat and grease, float to the surface, forming a scum layer.
- Bacteria living in the septic tank break down some of the organic solids into liquid components, helping to reduce the build up of sludge in the tank.
- Sludge and scum are stored in the septic tank rather than being allowed to flow out of the septic tank, where they would quickly create problems.
- The septic tank filter and/or baffles prevent scum and other floatable materials from flowing out to the GSF system.

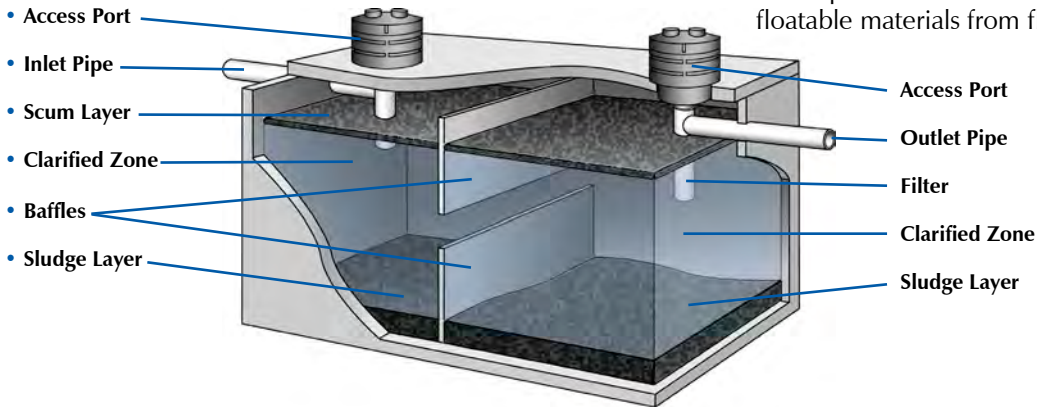

The GSF System

In a typical gravity-fed septic system, after primary treatment in the septic tank (ST), the effluent flows to the distribution box located just before the GSF system. In level systems, the distribution box divides the flow equally to the rows of GSF modules. In sloped systems, called serial distribution, the effluent flows first to the highest row and then, by overflow pipes, it passes to successively lower rows of GSF modules.

All GSF systems are installed on a layer of clean, medium to coarse specified sand. The effluent flows into the GSF modules through 4" perforated plastic pipes which are secured to the tops of the modules. A geotextile fabric covers the modules and distribution pipe assembly. This fabric prevents backfill materials and silt from entering the GSF modules.

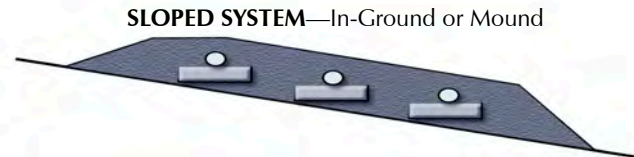
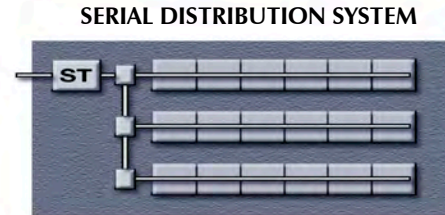
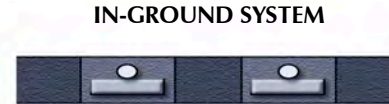
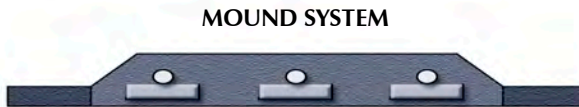
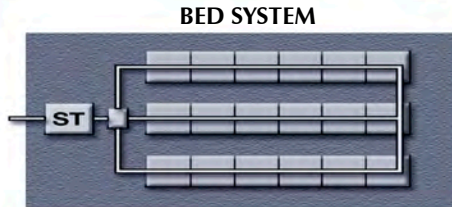
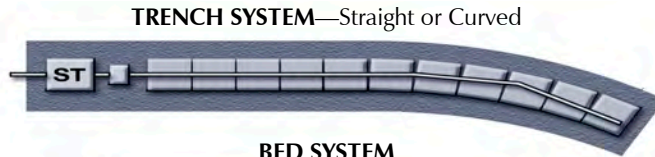

Septic Tank Effluent Filters

Your septic system may include an effluent filter, which may be located at the outlet of the septic tank, or in a separate tank located just after your septic tank. Effluent filters protect your GSF system from solids that may carry over from the septic tank during peak usage. By limiting the maximum size of particles entering the GSF modules to about 1/16 inch, they safeguard your system from unnecessary failure.

While effluent filters are partially self-cleaning, they must be thoroughly cleaned when the tank is inspected. When operating properly, they provide a fail-safe reminder that your tank needs pumping. Effluent filters may also be added to an existing system, either in the tank or externally. Filters must be installed before a pump chamber and should be easily accessible when the tank is serviced.

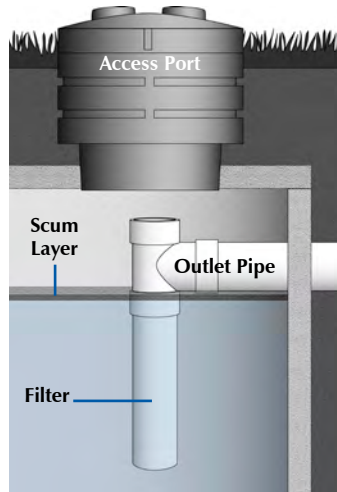

Pumped Systems

Some site conditions require that the system is installed at a higher elevation than the septic tank. When this is the case, an effluent pump and pump chamber are used to raise the sewage to the system's elevation. The pump chamber may be located in a separate tank, or it may be placed in a second compartment within the septic tank.

Effluent levels in the pump chamber are controlled by internal switches that turn the pump on and off, sending effluent to the system by dosing or pressure distribution.

System Care and Maintenance

SEPTIC TANK PUMPING

- Do not wait until your system shows signs of failure to have your septic tank pumped out. Waiting can mean complete clogging and an expensive repair bill. A septic tank filter will gradually slow down effluent flow over 2 to 3 years as a reminder that your tank should be serviced. Filters in residential systems usually need cleaning only as often as you pump the tank. Call a professional septic tank pumper to inspect your system.
- Clean your filter and pump your tank at a minimum of every 3 years.
- For a list of septic pumpers in your area, consult the yellow pages of your phone directory.
- If your system's access manholes are at ground level or are clearly marked or mapped, the job of pumping the tank should be fast and easy. While your tank is being inspected, ask the operator to examine the inlet and outlet baffles and/or septic tank filter. If anything is broken, have repairs done immediately. The inlet should also be checked to see if wastewater is continuously flowing into the tank from previously undetected plumbing leaks.
- It is not necessary to leave any of the sludge in the tank as "seed." Incoming sewage contains all the bacteria needed for proper operation. Acids or bleaches should not be used to clean the tank.
- The use of enzymes or other "miracle" septic system additives has not been shown to be of significant value. It has been observed that some of these additives can actually harm your system. Regular pumping remains the best insurance against system failure.
- Keep accurate records of your system's inspections and pumping in the space provided on page 14 of this manual.

Potential System Problems

SIGNS OF A FAILING SYSTEM:

- Slow draining toilets or fixtures
- Sewage backing up into the house
- Sewage odors near the field or tank
- Sewage breakout on to the lawn

Problems with septic systems can be quite difficult to analyze. Whenever your system is not operating properly, it is best to contact a trained professional, such as the installer who constructed your system or a licensed septic system pumper. Your area Eljen distributor will be able to recommend trained personnel to assist you. Keep a copy of your design plan on hand for use in analyzing any malfunctions. Always be sure to document any inspections or maintenance done to your system.

If toilets or fixtures are draining slowly and your system has a septic tank filter, check your service records to see if it has been too long between tank servicing and pumping. The pipe between the tank and the distribution box can also be checked for obstructions. If necessary, have your tank inspected, pumped, and clean the septic tank filter. Remember, the filter is there to protect your system.

If sewage is backing up into the house and you have a pumped system, have the pump and pump controls checked to make sure they are functioning properly. Make sure that the pump dose is not excessive and/or is set according to the original design. The distribution box can be exposed to determine if effluent is properly flowing out of the pump chamber. Also note that in winter, effluent can freeze in the force main or the distribution box and block sewage flow if the system is not used for a period of time.

If you detect sewage odors, sewage over or near the system, your system is overloaded. This may be caused by excessive water use and/or ground water intrusion into the septic tank through a leaking tank seam. Check your water consumption, check for leaky toilets or fixtures, and have your tank pumped so that the system can be checked for ground water intrusion into the tank, especially at seasonal high water time.

NOTE: Sewage odors coming from vent pipes are common with all types of disposal systems. Call us for information about activated charcoal filters that can be attached to the vent pipes.

Preventing System Problems

DO'S

- **DO** have your tank pumped at least every 3 years by a licensed septic tank pumper (listed in the yellow pages of your phone directory).
- **DO** practice water conservation. Promptly repair leaky faucets and toilets, run washing machines and dishwashers only when full, avoid long showers, and use water-saving features in faucets, showerheads and toilets.
- **DO** divert roof drains and surface water from driveways and hillsides away from the septic system. Keep sump pumps and household footing drains away from the septic system as well.
- **DO** take leftover hazardous household chemicals to your approved hazardous-waste collection center for disposal. Use bleach, drain and toilet bowl cleaners, and disinfectants sparingly and in accordance with product labels.
- **DO** learn the location of your septic tank and system's location and record it in the chart provided on page 14 of this manual. Keep a copy of your plan on file and attach a complete GSF System Card to a convenient place such as the main electrical panel.
- **DO** use the space provided on page 14 of this manual to keep a record of pumping, inspections and other maintenance.

Preventing System Problems

DON'TS

- **DON'T** drive or park over any part of your septic system. The area over the system should be left undisturbed with only a mowed grass cover. Roots from nearby trees or shrubs may clog or damage your system.
- **DON'T** put large amounts of cooking oil or grease into the system.
- **DON'T** put non-degradable materials such as disposable diapers, sanitary products, plastic, and cigarettes into the system.
- **DON'T** put poisons such as gasoline, oil, paint, paint thinner, pesticides, antifreeze, or other chemicals into the system.
- **DON'T** use commercial septic tank additives. These products usually do not help and some may hurt your system in the long run.
- **DON'T** wait for signs of system failure. Follow the maintenance advice in this manual.
- **DON'T** use garbage disposals unless your system has been designed according to the requirements of Eljen's GSF Design and Installation Guidelines.

System Details

Owner's Name, Address, Phone:	System Address, if Different than Owner's Address:
Contractor's Name, Address, Phone:	Engineer's Name, Address, Phone:
Contractor's License Number:	Engineer's License Number:
Installation Date:	Code Gallons / Day / Bedroom:
Number of Bedrooms:	Number of Occupants:
Design Flow in Gallons / Day:	Septic Tank Filter: <input type="checkbox"/> No <input type="checkbox"/> Yes, Location:
Number of GSF Modules:	Type of GSF Modules:
Number of Rows:	GSF Modules per Row:
System Design: <input type="checkbox"/> Level Bed <input type="checkbox"/> Trench <input type="checkbox"/> Serial Distribution <input type="checkbox"/> Pumped <input type="checkbox"/> Other:	
System Type: <input type="checkbox"/> Repair / Replacement <input type="checkbox"/> New Construction <input type="checkbox"/> Upgrade	
Structure Type: <input type="checkbox"/> Residential <input type="checkbox"/> Commercial	
System Use: <input type="checkbox"/> Year-Round <input type="checkbox"/> Seasonal	

Eljen Corporation Standard Limited Warranty for Septic Products

Each CSF module manufactured by Eljen Corporation and installed and operated as an on-site treatment system in accordance with Eljen Corporation's installation instructions, is warranted to the original system owner against defective materials and workmanship for two years from the date the system is inspected and activated for operation. In order to exercise its warranty rights, the original system owner must notify Eljen Corporation in writing at 125 McKee Street, East Hartford, Connecticut 06108 within 15 days of the alleged defect. Eljen Corporation will supply replacement modules determined by Eljen Corporation to be defective and covered by this Limited Warranty. Eljen Corporation's liability specifically excludes the cost of removal and/or installation of the modules; damage to the modules due to ordinary wear and tear, alteration, accident, misuse, abuse or neglect of the modules; the placement and or use of improper materials into the system containing the modules; failure of the modules or the septic system due to improper design, improper installation, excessive water usage, improper grease disposal, or improper operation; not using specified materials during system construction specifically sand meeting the ASTM C33 specification; or any other event not caused by Eljen Corporation. System owners shall consider the modules as single use, and re-use of modules that were previously installed in an activated on-site system shall void this Limited Warranty. For this Limited Warranty to apply, the modules must be installed in accordance with all site conditions required by state and local codes, all other applicable laws, and Eljen Corporation's installation instructions. This Limited Warranty and its remedies are exclusive and shall apply to no other party other than the original system owner.

THERE IS NO IMPLIED WARRANTY OF MERCHANTABILITY AND THERE IS NO IMPLIED WARRANTY OF FITNESS FOR BUYER'S PARTICULAR PURPOSE; THE IMPLIED WARRANTY OF MERCHANTABILITY AND THE IMPLIED WARRANTY OF FITNESS FOR BUYER'S PARTICULAR PURPOSE ARE HEREBY DISCLAIMED. THERE ARE NO WARRANTIES WHICH EXTEND BEYOND THE DESCRIPTION ON THE FACE HEREOF.

UNDER NO CIRCUMSTANCES SHALL ELJEN CORPORATION BE LIABLE TO THE SYSTEM OWNER OR ANY THIRD PARTY UNDER THIS AGREEMENT OR OTHERWISE FOR (a) ANY LOSS OR DAMAGE CAUSED BY OR ARISING OUT OF ANY DELAY IN FURNISHING ANY MATERIALS UNDER THIS AGREEMENT OR ANY ACT THAT IS NOT INTENTIONAL OR RECKLESS IN NATURE; OR (b) ANY INDIRECT, SPECIAL, EXEMPLARY OR CONSEQUENTIAL DAMAGES, REGARDLESS OF WHETHER ELJEN CORPORATION HAS BEEN ADVISED OF THE POSSIBILITY OF SUCH DAMAGES. WITHOUT LIMITING THE FOREGOING, SYSTEM OWNER OR ANY THIRD PARTY'S SOLE AND EXCLUSIVE REMEDY IN RESPECT OF THIS AGREEMENT AND THE MATERIALS FURNISHED HEREUNDER SHALL BE LIMITED TO THE REFUND TO SYSTEM OWNER OR ANY THIRD PARTY OF THE APPLICABLE FEES ACTUALLY PAID TO ELJEN CORPORATION UNDER THIS AGREEMENT WITH RESPECT TO THE PARTICULAR MATERIALS AT ISSUE. IN NO EVENT SHALL ELJEN CORPORATION'S LIABILITY HEREUNDER EXCEED THE APPLICABLE FEES ACTUALLY PAID TO ELJEN CORPORATION UNDER THIS AGREEMENT WITH RESPECT TO THE MATERIALS AT ISSUE.

This is the Standard Limited Warranty offered by Eljen Corporation. Any purchaser or potential system owner of modules should carefully read and understand this warranty prior to the purchase of the modules.



Innovative Environmental Products and Solutions Since 1970

www.eljen.com

Patented ©2009 0928-6/09-7.5M-H

Represented By: